

Key

- Existing hedge
- Existing vegetation
- Tree retention category A**
High quality with an estimated life expectancy of at least 40 years
- Tree retention category B**
Moderate quality with an estimated life expectancy of at least 20 years
- Tree retention category C**
Low quality with an estimated life expectancy of at least 10 years, OR young tree with a stem diameter below 150mm
- Tree category U**
Poor condition with an estimated life expectancy of less than 10 years
- RPA**
Minimum Root Protection Area
- Proposed tree removal**
To facilitate development. Refer to drawing number AIA05 for tree removal schedule.
- Proposed tree removal**
Due to poor condition. Refer to drawing number AIA05 for tree removal schedule.
- #
Approximate location
- v
Veteran tree
- Statutory Protection**
TPO (Tree Preservation Order), Conservation Area, Important Hedgerow etc.
- Tree protection fencing**
see Detail 1 and method statement

Trees have been surveyed and categorized as per the recommendations and guidance in BS 5837:2012 Trees in relation to design, demolition and construction.

This drawing is to be read in conjunction with the Arboricultural Survey report.

This drawing is to be reproduced in colour.

TREE REMOVAL SCHEDULE - REFER TO DRAWING NUMBER AIA05

FOR INFORMATION

Rev.	Date	Comments	Drawn	Checkd
A	02.12.2022	Updates to tree removals	KS	MS

SMEEDEN FOREMAN
Landscape Architecture • Ecology • Arboriculture

Stannard House, Low Moor Lane, Scotton, East Yorkshire, YO21 3SL
www.smeedenforeman.co.uk tel: 01430 862 589

Project Lancashire Central

Title Stainfield Lane Junction - Zone D West Arboricultural Impact Assessment 4 of 5

Project No. SF 3236	Drawing No. AIA04	Date 21.11.2022
Scale 1:500 @ A0	Checked by MS	Rev. A
Drawn by KS	Checked by MS	

The details shown on this drawing are confidential and the drawing is the exclusive property of Smeeden Foreman Limited. Copyright reserved. No part or substantial part of the drawing may be reproduced or transmitted in any form or by any means, electronic, mechanical, photocopying, recording, or by any information storage and retrieval system, without the prior written permission of Smeeden Foreman Limited. Smeeden Foreman Limited takes no responsibility for the use of the drawing for any purpose other than for which it was intended. This drawing must be read in conjunction with all other related drawings and documentation.

All dimensions are in millimetres unless stated otherwise. All dimensions should be verified on site prior to commencement of work.

Do not scale from this drawing.

All works involving materials must be in accordance with British Standards, CE Standards, Health & Safety at work act, and other relevant regulations & Bye Laws. All products to be used in accordance with the manufacturer's recommendations.

Smeeden Foreman Limited has not checked or verified, and shall therefore not be liable for any consequences which may be attributable to the execution of the drawing.

This document is provided to you by Smeeden Foreman Limited. If shown, have been reproduced from plans supplied to Smeeden Foreman Limited by third parties. Although care has been taken when producing this information, Smeeden Foreman Limited does not accept any liability for the accuracy or completeness of the information, which is provided as an advisory service only. The user of this information must ensure that they have taken appropriate measures prior to carrying out any mechanical excavation or other relevant operations.

ARBORICULTURAL METHOD STATEMENT

TREE PROTECTION FENCING

Tree protection fencing must be installed in the position as shown on the Tree Protection Plan before any other works on site can be undertaken.

Tree Protection Fencing should be set out as per Section 6.2 of BS5837: 2012 and will comprise a scaffold framework, consisting of vertical and horizontal scaffolds with vertical tubes spaced at a maximum of 3m intervals and driven securely into the ground. Weld mesh (Heras or similar) panels will be securely fixed on to this framework with scaffold clamps. Tubes will be firmed into holes in the ground made with post hole boring equipment. Bracing poles will be fixed to the inside of the barrier to ensure maximum rigidity, and should be located to avoid contact with structural roots.

See Detail 1 for details of the protective fencing to be employed in all circumstances, where existing site conditions allow. Fencing is to be erected as shown on the drawing. All fencing must be fixed in position with driven scaffold poles so that they cannot be moved during the construction period.

All-weather notices, A4 size, shall be attached to the tree protection fencing every 10m at 1.5m high with the words: 'Tree Protection Fence—strictly no access'.

MIXING AND STORAGE OF MATERIALS

All mixing and storage of cement and concrete will take place in a designated area, which will be located well outside the vicinity of the RPA.

All mixing operations must take place with ground protection in place, which will comprise a tarpaulin and ground boards. A spill kit (which is adequately equipped to deal with the materials being held on site) must be kept on site at all times. A supply of water must also be available during mixing operations (to dilute any spillage).

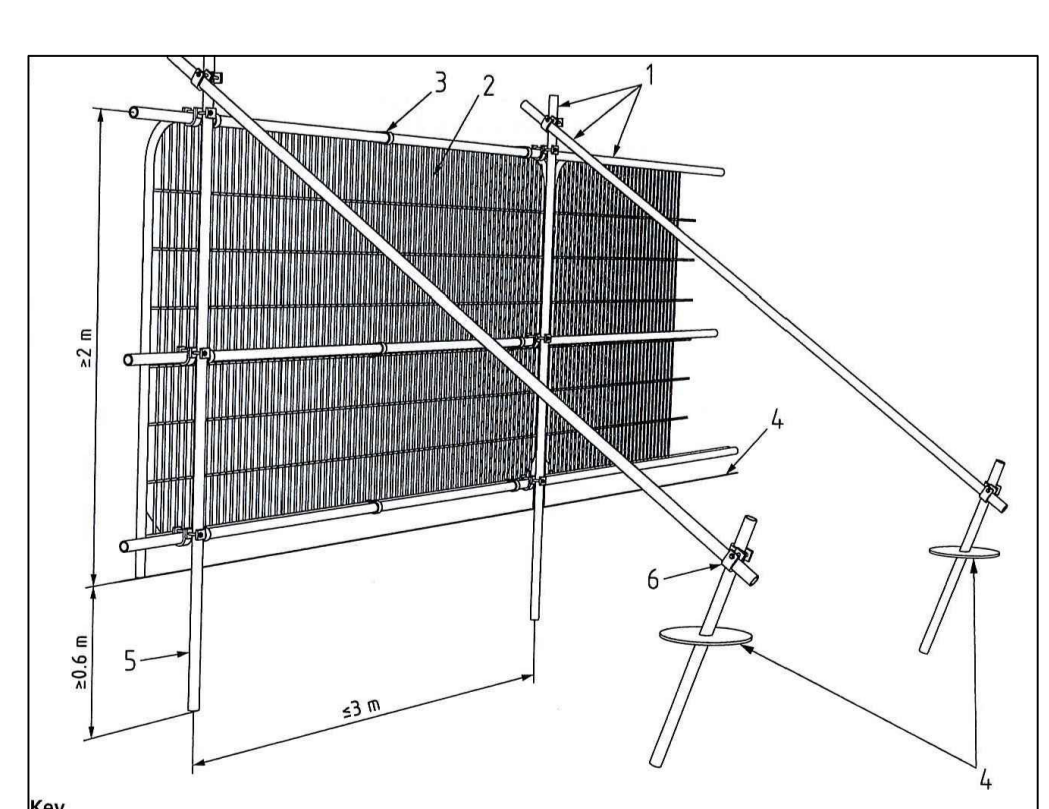

Detail 1 - Tree Protection Fencing (NTS)